

Fun Karts

MODEL: 3202 SERIES OWNERS MANUAL

WARNING:

Read Tecumseh Engine Owner's Manual and Important Rules for Safe Operation before Operating Vehicle

DANGER:

**YOU MUST ADD OIL TO THE ENGINE PRIOR TO USE!!!
20 oz. or 1 ¼ Pints (.6 Liters) OF SAE 30 MOTOR OIL**

This vehicle is sold for off-road use only. Before operating this vehicle, read all the instructions for safe assembly and operation as well as the instructions governing the engine and other portions of the vehicle. Pay close attention to all caution and warning labels on the Fun-Kart.

**For Replacements Parts Call:
1-888-926-6554 (U.S.) 1-888-707-1880 (Canada)**



Read These Important Rules For Safe Operation

NOTE: *All the items (1-33) below should be read and understood by the Operator and Parent. Failure to follow these instructions could endanger personal safety of the operator and any passenger.*

1. This vehicle is not licensable. **IT IS NOT TO BE OPERATED ON ANY PUBLIC ROAD, STREET, SIDEWALK or ALLEY.** To do so would be a violation of local law. This vehicle may be operated only on private property and upon areas approved by local law.
2. This vehicle should **NEVER** be operated indoors. The exhaust from the engine contains carbon monoxide, which is tasteless, odorless, and poisonous gas.
3. This Fun-Kart is not intended nor designed for racing.
4. **The operator of this vehicle should always wear a D.O.T approved helmet and other protective equipment as recommended by state and local laws. The operator should also wear face shields or goggles, boots, gloves, and other appropriate protective clothing.**
5. Unless otherwise specified in this manual, all screws, nuts, and bolts must be kept tight to ensure that the vehicle is in safe operating condition. The engine must be kept free of all dirt and other accumulations, paying particular attention to throttle linkage area.
6. Prevailing Torque type locknuts lose their locking capability with repeated use and require replacement. Ensure locknuts are functioning properly.

7. The tire pressure should be checked prior to each use. The recommended inflation pressure is the maximum tire pressure which is printed on the tire's sidewall. **Improper tire pressure may cause instability and may prevent proper braking or steering.**
8. Modification of this vehicle or removal of any original equipment or safety decals may render the vehicle unsafe or illegal. **Never remove any chained guard, or belt clutch guard.** These covers are for the riders' protection.
9. The vehicle should never be started without first checking to see that the throttle is in *idle* position. Do not start engine without verifying proper function of the throttle.
10. **Never attempt to start this vehicle without having the operator sitting in the proper position to ensure control of the kart.**
11. The operator's ability to operate this off-road vehicle safely is largely dependent upon the operator's ability to exercise proper judgement. An operator also must not be too small or too large for controlled operation. The operator must be at least 16 years of age and have understanding, mental capacity and physical capability to safely operate this vehicle. This vehicle should only be operated after mature, supervised instruction and sufficient practice in non-congested areas.
12. **This vehicle is designed for one operator and one passenger.** A passenger on any vehicle must be sufficient age, understanding, mental capacity, and physical capability to act to protect himself/herself, and wear a D.O.T approved helmet at all times. **This kart is not recommended for cumulative weights exceeding 250 pounds.**
13. The engine should be stopped when the vehicle is not in use.
14. **Loose clothing, long hair, or articles worn by any riders must be fully contained, or covered to prevent them from possibly being caught in rotating parts of the vehicle or the surrounding environment while riding. Failure to obey could endanger the personal safety of the Riders.**
15. **Do not place hands, feet, or any other part of the body or any clothing near the engine, muffler, wheels, chain, and other rotating parts of the vehicle while riding or running the engine.** Caution must be used in performing required maintenance on or near an operating engine. Special caution should be taken after the engine has been running, since the engine and other drive components may be extremely hot.
16. Wet, slippery, rough, or steep terrain is potentially dangerous and may result in injury if proper caution is not observed. Slow speeds are required to safely operate this vehicle under those conditions. The Operator must use mature judgement, skill, and experience to choose a speed suitable for the terrain and riding conditions.
17. **The Governor settings for this vehicle's engine must not be tampered with, altered or changed.** The governor is set by the engine manufacturer and limits the maximum speed of the engine (and vehicle) and protects the **engine** from damage. Excessive speeds are potentially dangerous to the rider and the engine.

18. Each time before using this vehicle, the fuel supply should be checked. The fuel tank should never be filled while the engine is running or while the engine is hot. Do not fill tank in closed area such as a garage, while smoking, or in the vicinity of an open flame. Do not overfill the tank. Always allow at least ¼ inch of space at the top of the tank for expansion. Never top off tank. Replace cap tightly to prevent spillage of fuel and potential fire hazard. After filling tank, move the vehicle at least 15 feet away from spot of filling before starting.
19. If the vehicle should start making unusual noise or vibrating abnormally, the engine should be stopped and the spark plug wire disconnected. The vehicle should then be checked for damage. Excessive noise or vibration is generally a warning of loose or worn parts.
20. When making repairs or adjustments to the vehicle which do not involve adjustments to the engine, the spark plug wire must be disconnected and kept away from the spark plug to prevent accidental starting. When working on or around or when restarting engine, use extreme caution to avoid contact with the muffler, cylinder head, or any other potentially hot area on or around the engine.
21. Always perform a Pre-Ride Inspection before starting the engine. See Pre-Ride Inspection in the manual.
22. The custom brush guard assembled on this vehicle is for deflecting loose vegetation and must not be removed.
23. When storing the vehicle, it must be kept in a place where gasoline fumes will not reach an open flame or spark. For long periods of storage, such as for winter, the fuel tank should be drained in the open, cool area. The engine must be allowed to cool before storage in any enclosure. Read and keep all printed material supplied with this vehicle. Timely and specific instructions and an Operators Manual revisions are included in supplements. If any printed material included is unclear, please call 1-888-389-5522 for assistance.
24. **Never operate this vehicle while under the influence of alcohol, drugs, or medication of any kind. Such operation could be dangerous to you and/or others.**
25. Always slow down while turning. High speed turning may cause loss of control, possible injury to the Operator.
26. ***Do not race, jump, and perform "stunt" riding or "spinouts" when operating the Fun-Kart. The Fun-Kart is not designed or intended for such operation.***
27. This manual provides guidelines for the assembly, maintenance, and operation of this Fun-Kart and is not intended as a service manual.
28. Assembly, maintenance, and/or repair of this Fun-Kart should only be performed by persons of sufficient mechanical skill, experience, and judgment (such as outdoor equipment dealers, motorcycle dealer/shops, or small engine dealers) so that no unsafe condition or modification is made.
29. Always use extreme caution when starting the engine. Avoid touching the engine, muffler, or drive components. These areas could cause burns on contact.
30. **Operator must always be appropriately supervised at all times while operating this vehicle.**

31. Riding your Fun-Kart requires skill acquired through practice over a period of time. Take the time to learn the basic techniques before attempting to ride the vehicle.
32. Ride only on safe and familiar terrain. Avoid loose gravel and rocks. Be careful on wet surfaces and allow for extra braking distance.
33. ALWAYS mount the caution flag provided on the Fun-Kart for safety purposes. This flag could help prevent dangerous situations.

Pay close attention to all *Caution* and *Warning* labels on the Fun-Kart.

ASSUMPTIONS OF RISK

The Owner Or Operator Assumes All The Risks Incident To Or Arising Out Of The Operation Of This Vehicle.

Failure To Follow And Comply With All Warnings May Cause Serious Injury Or Death

YERF-DOG Fun-Karts by Flexible Flyer

LIMITED WARRANTY

The *Limited Warranty* on this vehicle is in two (2) parts:

We offer the original purchaser of this product the following warranty:

PART 1

ENGINE

Tecumseh warrants the engine for (2) years, not Flexible Flyer. See Tecumseh Engine Owner's Manual. Engine repair, replacement parts, and warranty claims must be handled through an authorized dealer in your locality. Tecumseh has an extensive authorized sales and service dealer network. (See yellow pages of phone directory under "Engine-Gas").

PART 2

FRAME

The frame and related components are warranted by Flexible Flyer and are applied to any part found to be defective due to material and/or workmanship when inspected at the Flexible Flyer factory. Flexible Flyer will at its' option, repair or replace the defective parts to the original purchaser at no charge.

The warranty periods are as follows from the date of purchase:

- A. Frame for 90 days, Void if:
 - 1. Frame is broken or bent due to abuse (underside scraped abusively).
 - 2. Wheels are bent or broken due to impact.
 - 3. Spindles are bent due to impact.
 - 4. Paint is worn off of rear bumper indicating an extra rider.
 - 5. Axles are bent out of ordinary position either horizontally or vertically.
 - 6. Non-Factory altering of engine or it's components
- B. Bearings and sprocket for 30 days
- C. Clutch for 30 days against breakage of its parts. No warranty is applied for wear of clutch shoes or clutch bearings due to service.
- D. Throttle cable, brake cable, brake band, chain, tires, seat, shocks, fasteners and other components are not warranted because due to normal service they are subject to excessive wear and abuse.

All Warranties are voided if the vehicle has been altered in any way or is used in racing or competition, rented, used under abnormal conditions, or subject to abuse, misuse, neglect, or improper maintenance.

Flexible Flyer is not liable for any damage claim or liability claim, personal or otherwise resulting from the operation of this vehicle in any way.

**F.F. Acquisition Corp. YERF-DOG Warranty Dept.
1743 South Horne # 100
Mesa, AZ 85204**

**FOR REPLACEMENT PARTS PLEASE CALL:
1-888-926-6554 (U.S.) 1-888-707-1880 (Canada)**

ASSEMBLY

1. Complete the Fun-Kart registration and warranty confirmation on the back of this owner's manual and mail in within 10 days of purchase. The information is required when ordering parts.
2. *Steering Wheel* - Bolt the steering wheel to the anchor plate with fasteners provided in the parts bag included with the Fun-Kart. See "Steering Wheel Assembly Instructions" page 12.
3. *Seat* - Install the seat frame to chassis frame with fasteners provided in the parts bag. See "Seat Assembly Instructions" page 13.
4. *Brush Guard* - Bolt the brush guard to chassis frame with fasteners provided in the parts bag. See "Brush Guard Instructions" page 14.
5. *Foam* - Attach Foam to Brush Guard. See "Foam Attachment Diagram" page 15.
6. *Bolts* - Check the screws, nuts and bolts on your vehicle to see that all are tightened securely. For safe operating conditions, do periodic checks and tighten securely.
7. **Engine** - **Fill the crankcase with oil until it reaches the FULL mark on the dip stick. DO NOT fill above the FULL mark.** Approximately 20 oz. or 1¼ pints (.6 Liters) of SAE 30 weight oil. For additional information refer to Tecumseh engine manual for servicing the engine.
8. Fill fuel tank with regular gasoline, leaded or unleaded. Do not use premium gasoline. Do not overfill (No fuel in filler neck).
9. *Tire Pressure*

CHECK AIR PRESSURE IN TIRES!!

It is common industry practice to overinflate the tires. This is done to guarantee an airtight seal. Prior to riding the Fun-Kart for the first time, you may need to reduce the air pressure in the tires to the specifications stated below:

Rear Tires	10 PSI
Front Tires	12 PSI

Proper tire pressures will increase the life of the tire and enhance the performance of the Fun-Kart.

Driving on asphalt or concrete will significantly reduce the life of the tire!!

PRE-RIDE INSPECTION

WARNING - *Perform this pre-ride inspection everyday before riding the vehicle. If not performed, serious damage to the vehicle and personal injury may result.*

1. *Engine Oil Level* – Add oil if required. Check for leaks. Tighten filler cap securely.
2. *Fuel Level* – Add fuel if necessary. Do not overfill (no fuel in filler neck). Replace cap tightly. Check for leaks. Do not mix oil with gas. Only refuel when engine is off and cool.
3. *Brakes* – Perform a Brake Test: Sit in the vehicle with the brake actuated by pressing on the brake pedal. Start the engine with the ignition switch on. Increase the engine RPM gradually to ensure the brake is effective. Do not operate this Fun-Kart unless the brake is working properly.
4. *Tires* – Check conditions and pressure.
5. *Drive Chain* – Check condition, tension, lubricate as necessary.
6. *Throttle* – Check for smooth operation. Assure throttle “snaps” back to idle. Also, check for frayed cable or damaged cable conduit. If either condition exists replace the cable assembly before riding.
7. *Stop Switch* – Perform this stop switch test. While the engine is running, move the steering column remote stop switch to the “OFF” position. If this does not stop the engine, move the engine remote switch to the “OFF” position. If the engine is not equipped with an engine remote switch, pull the spark plug wire. Check to insure that the stop switch wire is attached to the terminal on the engine. **Do not operate this vehicle with a stop switch that is not functioning properly.**
8. *All Nuts, Bolts and Fasteners* – Check wheels to assure that all axle nuts and lug nuts are tightened properly. Check and tighten all other fasteners as necessary. Regularly check set screws on sprockets and drum.
9. *Guards* – Ensure all protective guards are in place. **Never remove any chain guard, or clutch guard.** Each of these covers have a protective purpose, if removed it could endanger the personal safety of the operator or passenger.
10. *Steering System* – Ensure that it turns freely.

STARTING INSTRUCTIONS

NOTE: *Do not attempt to start or operate this machine without being completely familiar with all controls necessary to operate this vehicle safely. Do not start the engine before reading and understanding all the rules, warnings, and instructions in this manual.*

1. Before starting the engine, the operator should be seated in the Fun-Kart. If the rider is not seated in the vehicle, it should be placed against a stationary object and started.
2. Do not start the engine before checking to make sure the throttle assembly is in the idle position. Warning – Each time prior to starting the engine, check throttle assembly to ensure that when the throttle pedal (right side) is pushed all the way forward the assembly is working smoothly and returns to idle when released. Do not operate if pedal and engine throttle linkage fail to return to idle.
3. To start a cold engine, pump the engine primer “3” times. If the engine is hot, priming may not be necessary to restart the engine.
4. Pull recoil starter rope sharply. See Tecumseh engine owner’s manual. Do not flood the engine by continuously pulling the starter rope. If engine does not start after two or three pulls of the starter rope, wait a few minutes then repeat the above procedures.

OPERATIONAL SAFETY TIPS

TURNING MANUEVERS

The new rider must learn to shift his weight and control the throttle to allow the rear tires to negotiate the turn. This is the primary technique to be mastered in riding this vehicle. Practice turning at slow constant speeds. Defer increased speeds until you are confident of your proficiency and are intimately familiar with the terrain.

Steer in the direction of the turn, and lean your body to the inside of the turn in order to maximize front tire traction. Use the throttle to maintain posture throughout the turn.

Incorrect turning techniques may cause the front tires to slide straight ahead without affecting the vehicles direction of travel. If this should occur, come to a stop, then resume the technique outlined above.

If the front wheels tend to skid in mud, sand, or snow, you may be able to improve control by releasing the throttle and allowing the vehicle to coast through the turn.

If rear wheel inadvertently skid sideways, correct your slide by steering in the direction of the skid, if you have room to perform this maneuver safely. Avoid braking or accelerating until you have control.

To avoid skids while traveling on slippery terrain, the rider must exercise a high degree of caution. Turning maneuvers on slippery terrain are more hazardous than those performed under full traction and must be done slowly.

PREVENTIVE MAINTENANCE

STORAGE

In the event your vehicle is not to be operated for a period in excess of 30 days and at the end of riding season prepare for storage as follows:

WARNING- Do not drain fuel while engine is hot. Be sure to move vehicle outside before draining fuel.

1. Drain fuel tank and remove all fuel remaining in the tank by using a suction device or by soaking up the fuel with a clean rag or towel. Remove all fuel remaining in the carburetor by allowing engine to run out of fuel. Do not perform any fuel removal procedure while smoking or near an open flame. Dispose of any rags or towels properly.
2. Lubricate engine cylinder by removing the spark plug and pouring an ounce of lean lubricating oil through the spark plug hole into the cylinder. Crank the engine slowly to spread oil and replace spark plug.
3. Do not save or store gasoline over winter. Using old gasoline that has deteriorated from storage will cause hard starting and affect engine performance.
4. When the vehicle is removed from storage re-read the owner's manual, perform any assembly required, and perform a pre-ride inspection. See Pre-Ride Inspection section of this manual.

GENERAL

Just as your automobile needs professional, mechanical maintenance from time to time, so does this vehicle. Replacement of the spark plug and ignition points is made necessary by normal use. Professional air-cooled engine service is easily obtained. Check your phone book yellow pages under "Engine Gasoline".

SERVICE INSTRUCTIONS

Engine Lubrication – You must change the oil in the crankcase after the first two hours of operating your new engine and after each 25 hours of use thereafter. That will insure proper lubrication in internal parts and prevent costly repairs due to excessive wear. Refer to Engine Maintenance Instructions.

Kart Lubrication – Every two or three hours of use lubricate the following items with several drops of oil; steering bearing points, brake rod pivot points, pedal pivot points, steering spindles, and steering rod ends. Use the same grade of lubricating oil that is used in the engine crankcase.

Chain Lubrication – **For the best chain life, it should be lubricated with a graphite type of lubricant such as the spray-on type which evaporates leaving the graphite on the chain.** Using oil or grease on the chain in dusty or sandy riding conditions may cause dirt particles to stick to the chain resulting in rapid wear from abrasion.

Front Wheel Replacement – Care must be used when replacing wheels. **Do not over tighten nuts.** It is only necessary to tighten the nuts so that the wheel turns freely on the axle with minimum endplay. If the wheel does not turn freely the nut is too tight.

Rear Wheel Replacement – Loosen the large locknut in the center of the wheel to remove the rear wheel.

Chain Adjustment – After the first two hours of operation, check the chain adjustment and readjust it if it has more than 1/2" flex. Loosen the engine clamp nuts and slide the engine forward to tighten chain.

**For Replacement Parts Please Call:
1-888-926-6554 (U.S.) 1-888-707-1880 (Canada)**

SUSPENSION MAINTENANCE

The Suspension System on your Fun-Kart is specifically designed and set up for the smoothest possible ride, while maintaining top performance and kart durability. Your Fun-Karts suspension system uses four shock absorbers, two on the front suspension and two on the rear suspension, to comfortably tackle rough terrain.

The two front shock absorbers affect the camber or slant of your front tires. You may have noticed that your new Fun-Kart has an *extreme outward camber* or slant of the front tires as shown in **Figure A**. This is **normal**. They were set this way at the factory for ensuring maximum tread life on the front tires. There are three important reasons for this outward camber:

1. The weight of the driver and/or passenger is not on the Kart.

The added weight of the driver and/or passenger pushes the front and rear suspension down.

2. The Fun-Kart is not in motion.

When the Kart is in motion, the front suspension is forced down slightly.

3. The shock absorbers are new and not “broken in”.

Your new Fun-Kart needs at least one hour of use to “break in” the shocks and level out the tires. After the first 30 minutes of use, the outward camber may be reduced by one half. After 1 hour of use the tires may have *almost no or slight outward camber* as shown in **Figure B**.

When your Fun-Kart gets an *inward camber* on the front tires from shock wear as shown in **Figure C** and steering becomes difficult, the shocks will need to be readjusted. Adjust the front suspension to a *slight outward camber* as shown in **Figure B** by increasing the shocks. Adjust the shocks by following the “Shock Absorber Adjustment “ instructions below. When your shocks cannot be adjusted any tighter, they must be replaced.

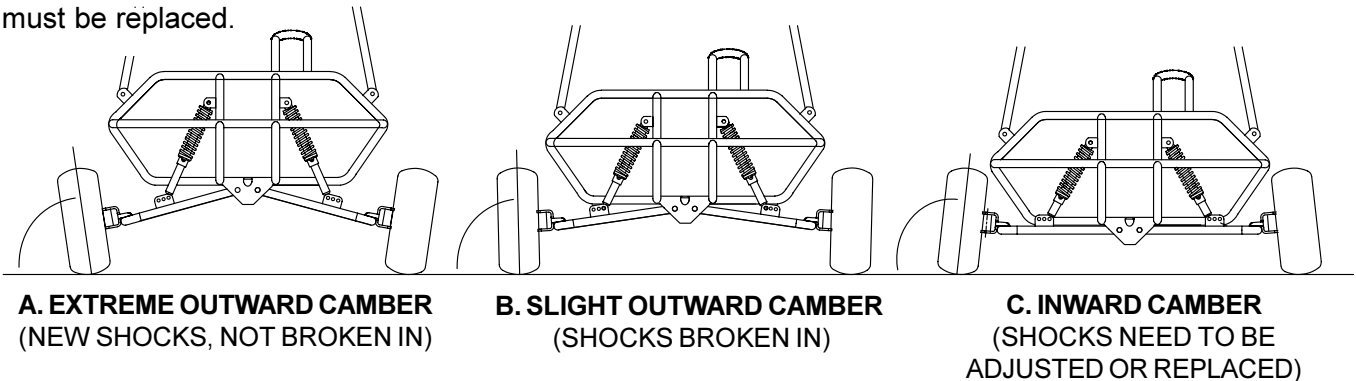

Your Fun Kart has an added feature on the A-Arms for three quick Camber Adjustments **Figure D**. Note: The factory attaches the shocks at position 2. You may choose to move them to position 1 and adjust shocks to set at Slight Outward Camber (Riding Position) until the shocks “break in” then either readjust the shocks as shown in “Shock Absorber Adjustment” or move to position 2. Shocks may bottom out (cannot be adjusted any tighter) before you need to set to position 3.

To adjust: Remove 3/8” x 1-3/4” Bolts and 3/8” Nylock Nuts attaching the bottom of the Shocks to the Three Hole Brackets and move to desired hole then reattach Shocks. Tighten Bolts.

NOTE: Outside holes can be used for new kart display purposes with new shocks. (Setting at “NO CAMBER”)

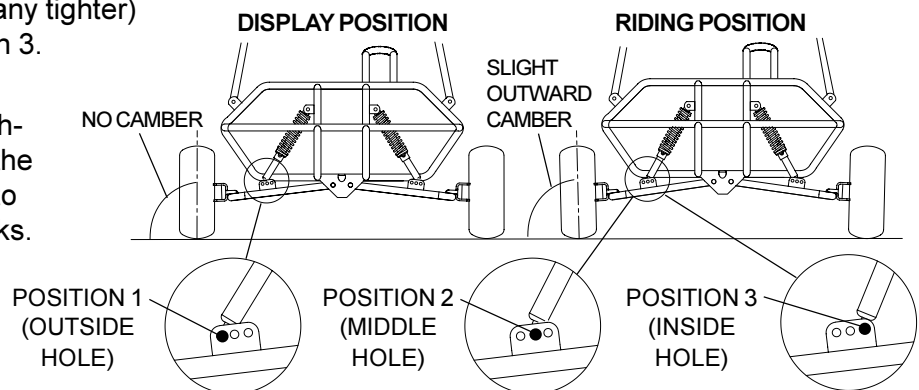

D. THREE QUICK CAMBER ADJUSTMENTS

SHOCK ABSORBER ADJUSTMENT

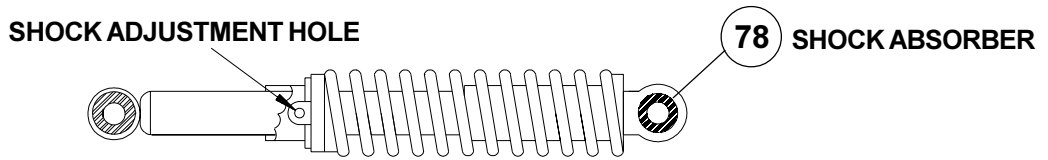

1. Locate the SHOCK ABSORBERS (78) at the front and rear of the FUN-KART
2. The SHOCKS are pre-set for normal conditions at the factory.
3. Locate the SHOCK ADJUSTMENT HOLE at the base of the spring.
4. Place the end of a narrow screwdriver in the SHOCK ADJUSTMENT HOLE.
5. Turn the SHOCK ADJUSTMENT HOLE counter-clockwise around the SHOCK to decrease shock absorption.
6. Turn the SHOCK ADJUSTMENT HOLE clockwise around the SHOCK to increase shock absorption.
7. Experiment with the adjustment until the desired effect is attained.

STEERING WHEEL ASSEMBLY INSTRUCTIONS

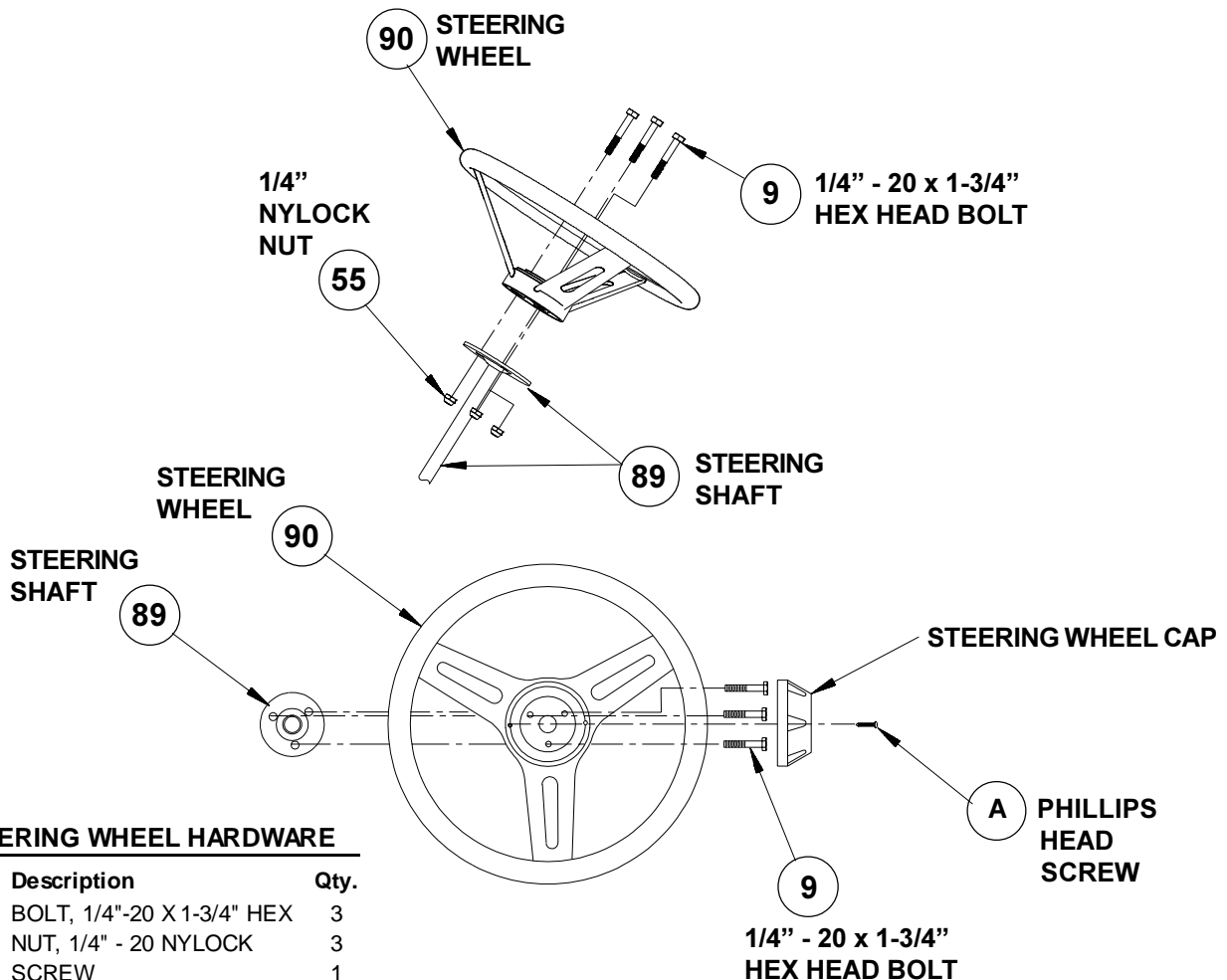

STEERING WHEEL HARDWARE

Item	Description	Qty.
9	BOLT, 1/4"-20 X 1-3/4" HEX	3
55	NUT, 1/4" - 20 NYLOCK	3
A	SCREW	1

SEAT ASSEMBLY INSTRUCTIONS

1. Locate the SEAT ASSEMBLY with LAP BELTS, and SHOULDER BELTS.
2. Align the STUDS on the bottom of the SEAT ASSEMBLY with the SEAT TAB HOLES on the FUN-KART FRAME.
3. Insert the STUDS into the SEAT TAB HOLES.

4. Secure the SEAT ASSEMBLY using four 5/16" FLAT WASHERS (101) and four 5/16" NYLOCK NUTS (60).

NOTE: The ends of the SHOULDER BELTS will be mounted onto the front of the MAIN BRUSH GUARD in step 6 of the BRUSH GUARD ASSEMBLY INSTRUCTIONS on page 14.

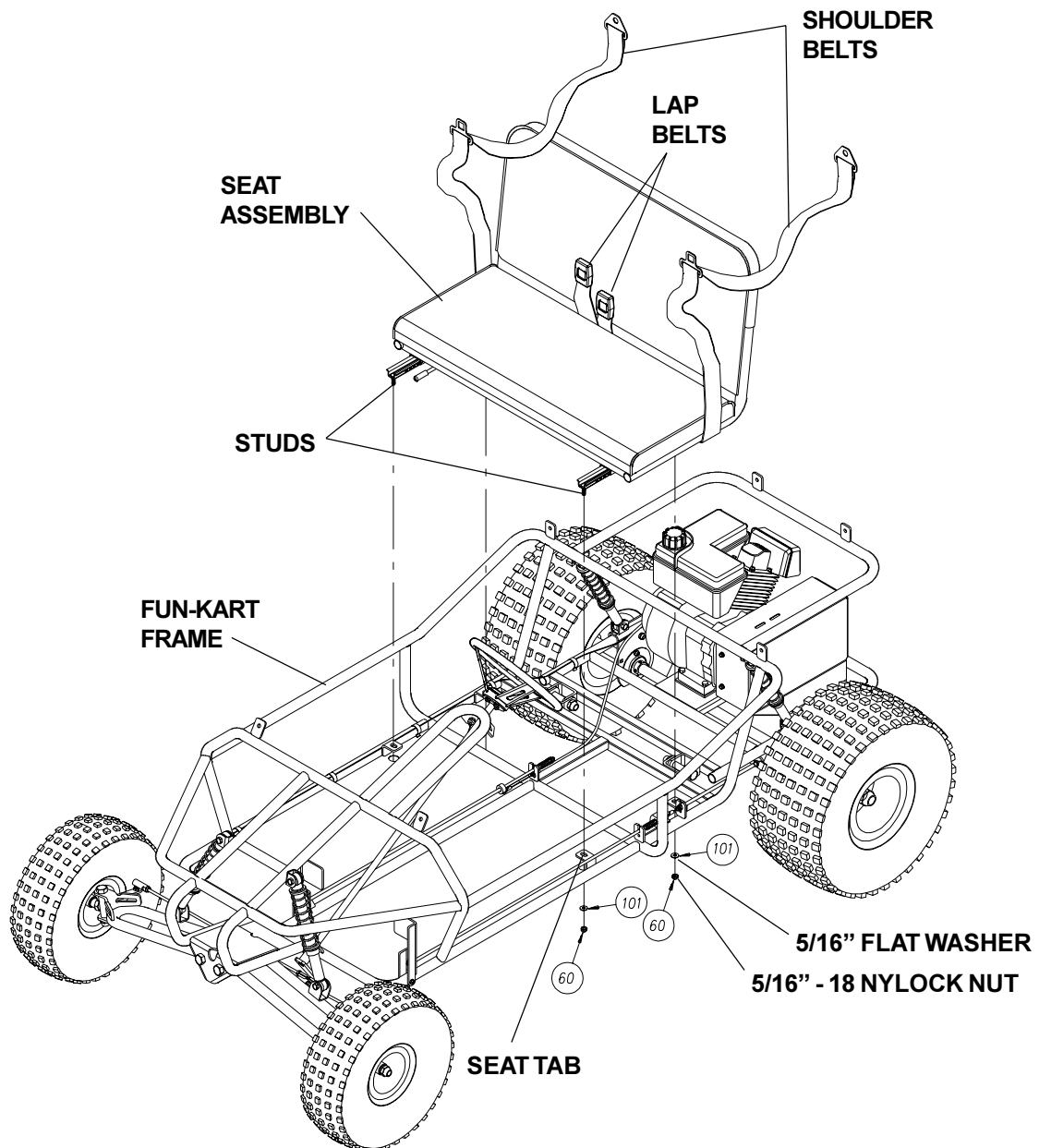

BRUSH GUARD ASSEMBLY INSTRUCTIONS

1. Secure the MAIN BRUSH GUARD (32) to the middle tabs on the FUN-KART FRAME, behind the SEAT, using the hardware shown.
2. Secure the REAR BRUSH GUARD (33) and SAFETY FLAG (47) to the rear tabs on the FRAME using the hardware shown.
3. Align holes and secure the REAR BRUSH GUARDS (33) to the top of the MAIN BRUSH GUARD (32) using the hardware shown.
4. Secure the FRONT BRUSH GUARD (31) to the front tabs on the FRAME using the hardware shown.
5. Join and secure the FRONT BRUSH GUARD (31) to the ends of the REAR BRUSH GUARDS (33) using the hardware shown.
6. Mount the ends of the SHOULDER BELTS to the front of the MAIN BRUSH GUARD (32) using the hardware shown.
NOTE: Do not overtighten the hardware attaching the ends of the SHOULDER BELT. The BELT must rotate.
7. Mount the HEADREST CUSHION (49) to the MAIN BRUSH GUARD (32) using the hardware shown.

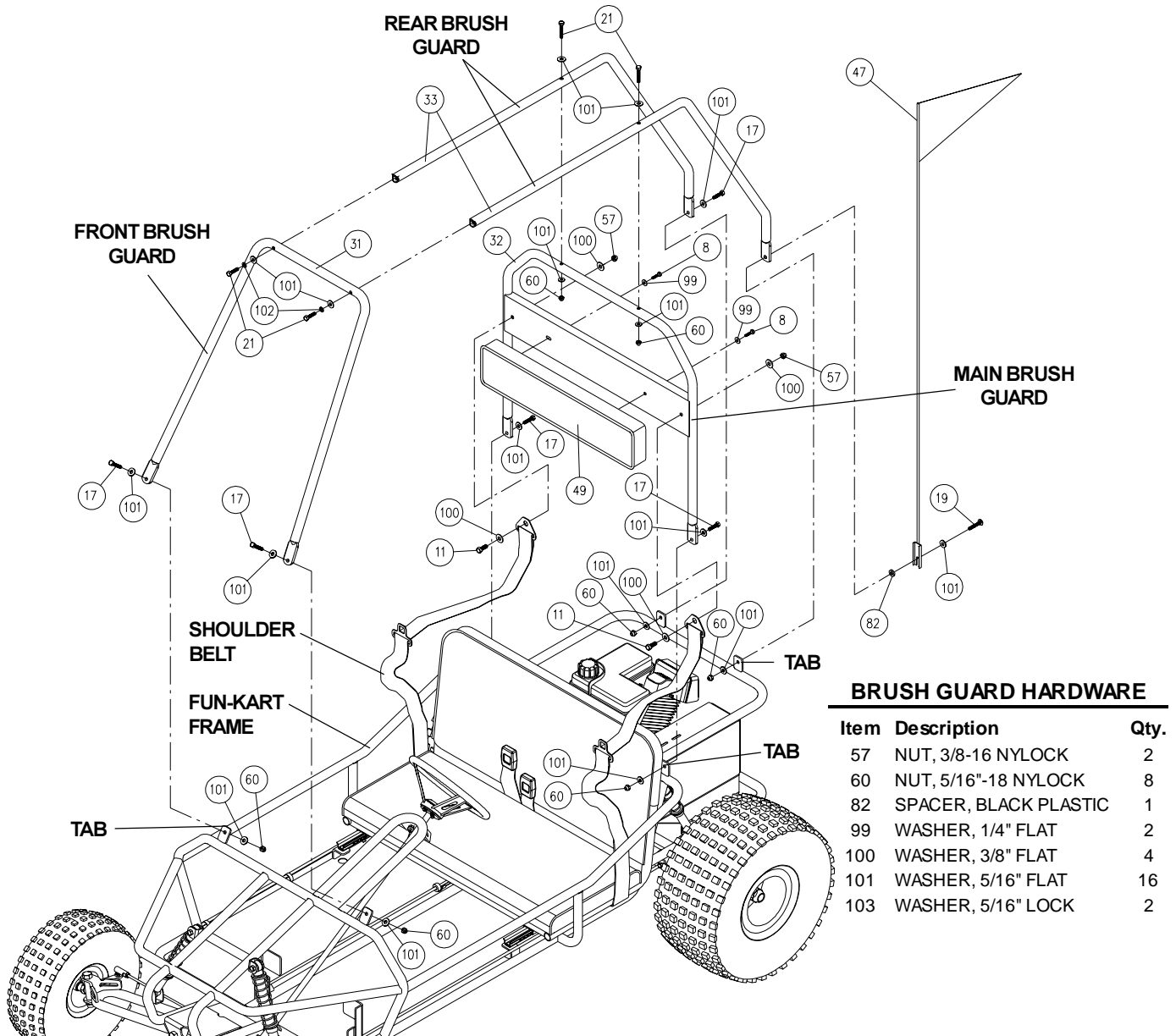

BRUSH GUARD HARDWARE

Item	Description	Qty.
57	NUT, 3/8-16 NYLOCK	2
60	NUT, 5/16"-18 NYLOCK	8
82	SPACER, BLACK PLASTIC	1
99	WASHER, 1/4" FLAT	2
100	WASHER, 3/8" FLAT	4
101	WASHER, 5/16" FLAT	16
103	WASHER, 5/16" LOCK	2

FOAM ATTACHMENT DIAGRAM

Attach FOAM (48) to the BRUSH GUARDS using CABLE TIES (35) as shown.

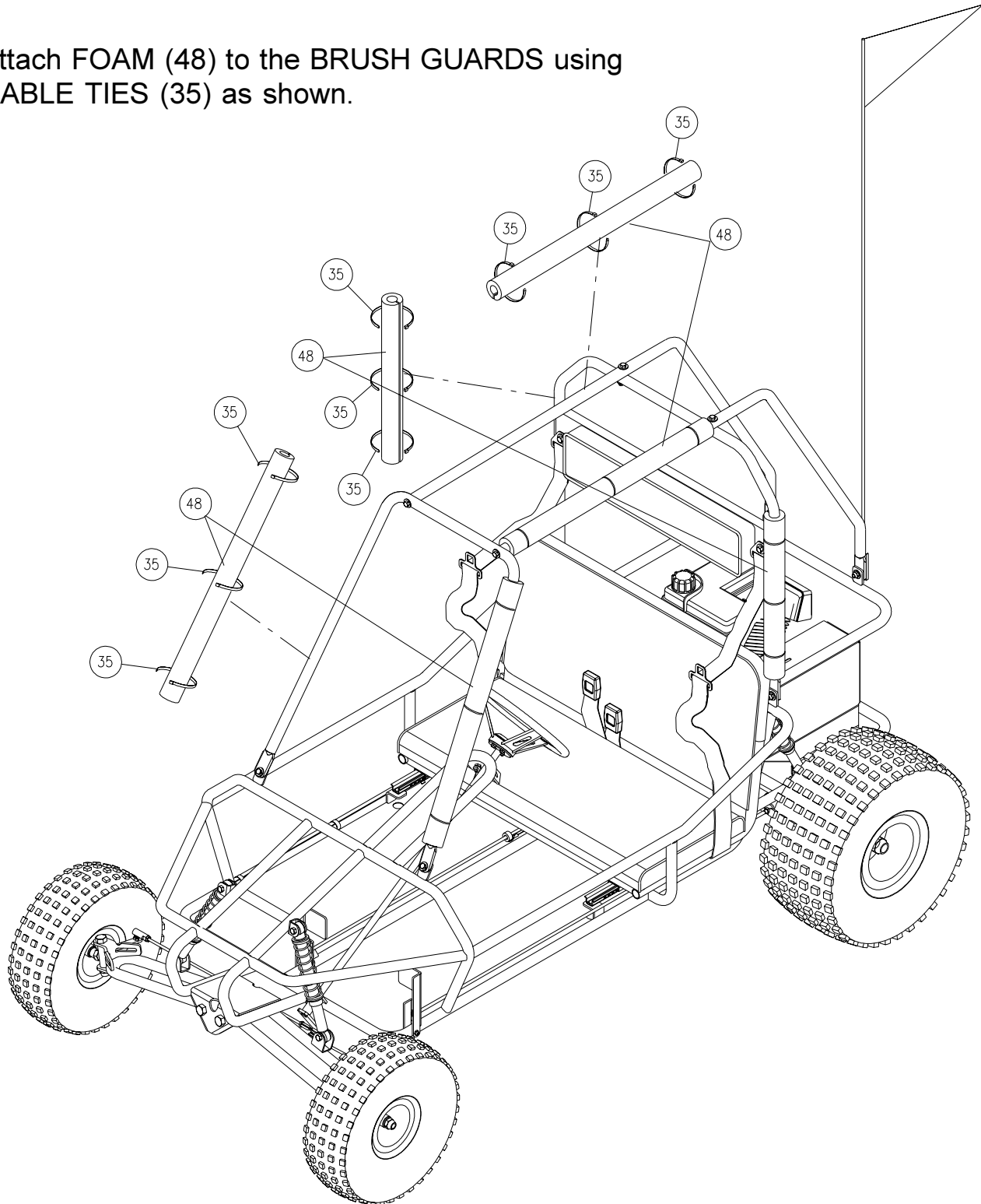

3202 SERIES REPLACEMENT PARTS IDENTIFICATION

Item	Part No.	Description	Item	Part No.	Description
1	32015006	A-ARM, LEFT, BLACK	56	HH10014	NUT, 1-14 THIN NYLOCK
2	32015160	A-ARM, RIGHT, BLACK	57	001205P	NUT, 3/8-16 NYLOCK
3	01132	AXLE SHAFT, GROOVED	58	00995	NUT, 3/8-16, JAM
4	H93110W	BEARING RETAINER	59	HH37524	NUT, 3/8-24 THIN NYLOCK
5	H92010W	BEARING, 1" I.D.	60	HH1256T	NUT, 5/16-18 NYLOCK
6	H99502W	BEARING, 5/8" I.D.	61	HH62518	NUT, 5/8-18 THIN NYLOCK
7	Q43203W	BELT, DRIVE	62	01226	NUT, 5/16-18 JAM
8	22001600	BOLT, 1/4-20 X 0.75 HEX	63	01225	BOLT, 5/16-18 X 5/8" HEX
9	H32503W	BOLT, 1/4-20 X 1.75 HEX	64	01133	SPACER 0.78 ID DRIVE
10	H33137W	BOLT, 3/8-16 X 1.00 CARRIAGE	65	32015306	PITMAN ARM, BLACK
11	H61610W	BOLT, 3/8-16 X 1.00 HEX	66	01528	RETAINING RING, 1" HEAVY DUTY
12	00922	BOLT, 3/8-16 X 1.50 HEX	67	H91470W	RETAINING RING, 1/4"
13	22000300	BOLT, 3/8-16 X 1.75 HEX	68	00925	WIRE, 16GA X 107" KILL SWITCH
14	00920	BOLT, 3/8-16 X 2.00 CARRIAGE	69	27000100	ROLL PIN, 1/4 X .875
15	22000900	BOLT, 3/8-16 X 2.00 HEX	70	H32505W	SCREW, 1/4-20 X 0.50 SLOTTED HEX
16	H95188W	BOLT, 5/16-18 X 0.75 CARRIAGE	71	22001400	BOLT, 1/4-20 X 1.5 SHOULDER HEX
17	2200040	BOLT, 5/16-18 X 1.00 HEX	72	H93200W	SCREW, 1/4-28 X 0.250 SET
18	H93290W	BOLT, 5/16-18 X 1.50 CARRIAGE	73	01964	SPACER TUBE, BEARING
19	2200030	BOLT, 5/16-18 X 1.50 HEX	74	00934	SEAT CUSHION
20	H33135W	BOLT, 5/16-18 X 1.75 HEX	75	00927	SEAT FRAME, BLACK
21	00996	BOLT, 5/16-18 X 2.25 HEX	76	H92740W	SEAT RAIL, 1 PAIR
22	H33136W	BOLT, 5/16-24 X 0.50 HEX	77	26000900	SEATBELT, RETRACTABLE
23	H36254W	BOLT, 5/8-18 X 3.75 HEX	78	02972B	SHOCK ABSORBER
24	22001700	BOLT, 5/8-18 X 7.00 HEX	79	00951	SLEEVE, 13-1/8" BLACK PLASTIC
			80	00919	SLEEVE, 2-3/8" BLACK PLASTIC
26	H91820W	BRACKET, FOOT PEDAL, LEFT	81	00983	SLEEVE, 4-5/8" BLACK PLASTIC
27	H91830W	BRACKET, FOOT PEDAL, RIGHT	82	001467P	SPACER, BLACK PLASTIC
28	H92130W	BRAKE BAND	83	00513	SPACER, SPINDLE
29	01759	BRAKE CABLE, 23"	84	32010605	SPINDLE, LEFT, BLACK
30	H92140W	BRAKE DRUM, 4" DIAMETER	85	32010505	SPINDLE, RIGHT, BLACK
31	00944	BRUSH GUARD, FRONT, BLACK	86	H55030W	SPRING, 1/2 X 3.00 COMPRESSION
32	00936	BRUSH GUARD, MAIN, BLACK	87	H92541W	SPROCKET, 10 TOOTH
33	00941	BRUSH GUARD, REAR, BLACK	88	23001100	SPROCKET, 60 TOOTH
34	31004600	CABLE ATTACHMENT, BLACK	89	00981	STEERING SHAFT, BLACK
35	M12501W	CABLE TIE, 11" BLACK	90	H92561W	STEERING WHEEL, 13"
			91	00954	SWING ARM, BLACK
37	M13501W	CABLE TIE, 23"	92	36000700	THROTTLE CABLE, 40"
38	M01001W	CABLE TIE, 3-1/4" BLACK	93	02064	TIE ROD, LEFT, 9"
39	00994	CHAIN, DRIVE, #40, 70 LINKS	94	02063	TIE ROD, RIGHT, 20"
40	00982	CHASSIS, BLACK	95	46000030	TIRE, FRONT, GREY, TURF TREAD
41	03258	CLUTCH MOUNT PLATE, BLACK	96	46000040	TIRE, REAR, GREY, TURF TREAD
42	H91480W	COLLAR, 7/16" BORE X 7/8" O.D.	97	Q43200W	TORQUE CONVERTER, DRIVEN
43	02907	COVER MOUNT BRACKET, BLACK	98	Q43201W	TORQUE CONVERTER, DRIVER
44	00918	DECAL KIT, RED & YELLOW	99	001812P	WASHER, 1/4" FLAT
45	02908	DRIVE COVER, BLACK	100	001616P	WASHER, 3/8" SPECIAL FLAT
46	Q43160W	ENGINE, 6.0 H.P. TECUMSEH	101	001618P	WASHER, 5/16" FLAT
47	H92700W	FLAG, SAFETY	102	H53132W	WASHER, 5/16" INTERNAL TOOTH
48	M72038W	FOAM, 2" X 72" BLACK	103	00891P	WASHER, 5/16" LOCK
49	00940	HEADREST CUSHION	104	H56251W	WASHER, 5/8" NARROW FLAT
50	02014	JACKSHAFT, 5/8" WITH WASHER	105	H92690W	WIRE CLIP
51	H92250W	KEY, 1/4 X 1/4 X 2.00	106	00925	WIRE, 16GA X 107" KILL SWITCH
52	01134	KEY, 3/16 X 3/16 X 3.25			
53	Q33100W	KILL SWITCH	02604		4-CYCLE ENGINE OIL
			00948		OWNERS MANUAL
55	001203P	NUT, 1/4-20 NYLOCK	H91780W		OWNERS MANUAL, ENGINE

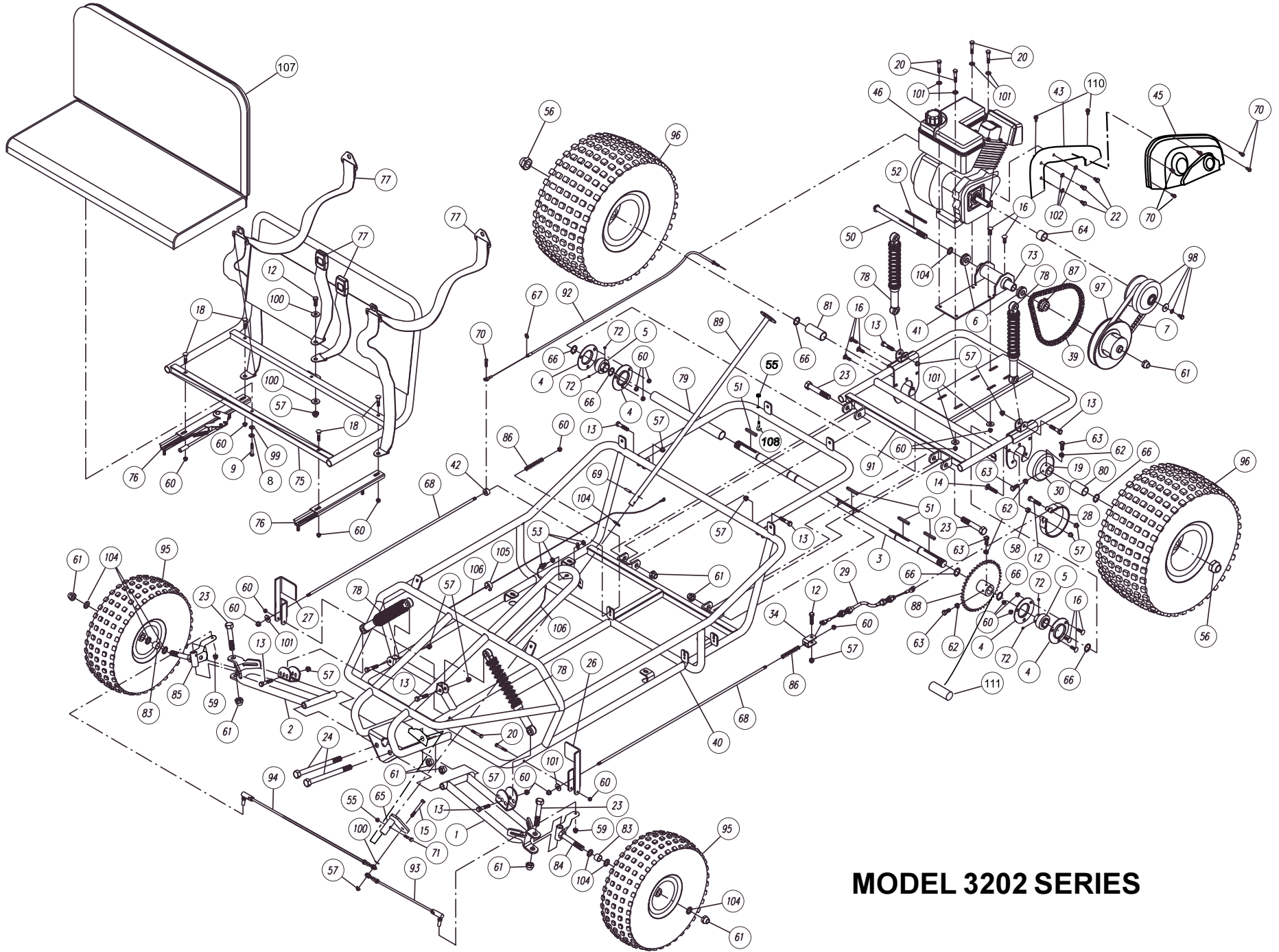

MODEL 3202 SERIES

VEHICLE REGISTRATION AND WARRANTY CONFIRMATION

IMPORTANT!

Please return this information within 10 days of purchase to validate your warranty.

Return to:

**F.F. Acquisition Corp.
YERF-DOG Warranty Dept.
1743 South Home #100
Mesa, AZ 85204**

Thank-you for purchasing this fine YERF-DOG product. With proper use, maintenance and service this kart will bring many years of fun and enjoyment. Please complete this vehicle registration and warranty confirmation form to ensure protection under the terms and conditions of the warranty and to verify ownership of this product.

To ensure maximum safety while operating your YERF-DOG Fun Kart, observe the following precautions:

**OPERATE THIS KART OFF ROAD ONLY
ADULT SUPERVISION FOR OPERATORS UNDER 16 YEARS OLD
WEAR A D.O.T. APPROVED HELMET, PROTECTIVE EYE WEAR, AND CLOTHING
SECURE LONG HAIR AND LOOSE CLOTHING; KEEP ARMS, LEGS, AND FEET INSIDE THE KART
DO NOT OPERATE UNDER THE INFLUENCE OF DRUGS OR ALCOHOL**

To ensure maximum owner satisfaction and understanding of this product, you should:

**READ OWNERS MANUAL BEFORE OPERATING KART
REVIEW AND FULLY UNDERSTAND THE KART AND ENGINE WARRANTIES
INSPECT THE KART UPON DELIVERY
SECURE A COMPLETED COPY OF THIS CERTIFICATE FOR YOUR RECORDS**

In signing this document, the purchaser acknowledges that he/she understands the warranty limitations, safety, and maintenance guidelines outlined above and in the owner's manual and, therefore, agrees that all riders/operators will adhere to these specifications.

Model No.

Serial No.

Date of Purchase

First Name

Initial

Last Name

Street Address

City

State

Zip Code

Home Telephone Number

Parent's Signature

(Please enclose a copy of your proof of purchase.)
